







PumpGuard Plus



Automated Duplex Pump Controller and Alarm System

Patent No. 5,449,274
U.L. Listed

The Guardian of Dry Basements *...and Your Peace of Mind* PumpGuard Plus Features

-  Automatically alternates both pumps every cycle for even wear
-  Features an alarm override circuit and switch that will not only sound an alarm but also automatically calls for second pump in sequence when activated
-  Audible alarm with light
-  Dry contacts for remote alarm monitoring
-  Optional dialer for remote alert
-  Optional battery back-up to run entire system
-  U.L. Listed and made in U.S.A

TYPICAL INSTALLATION

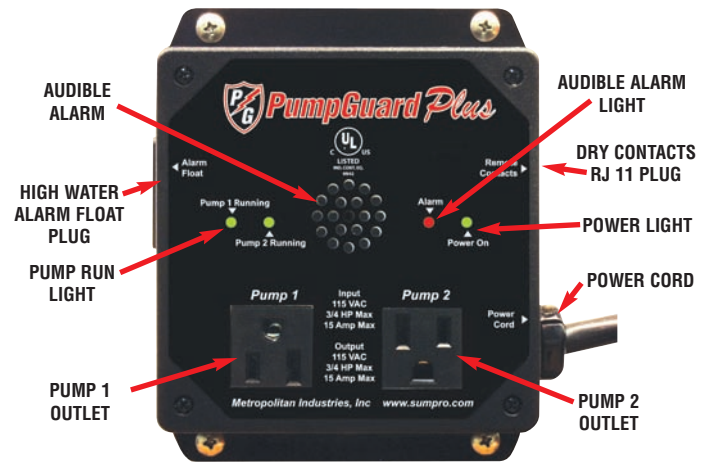
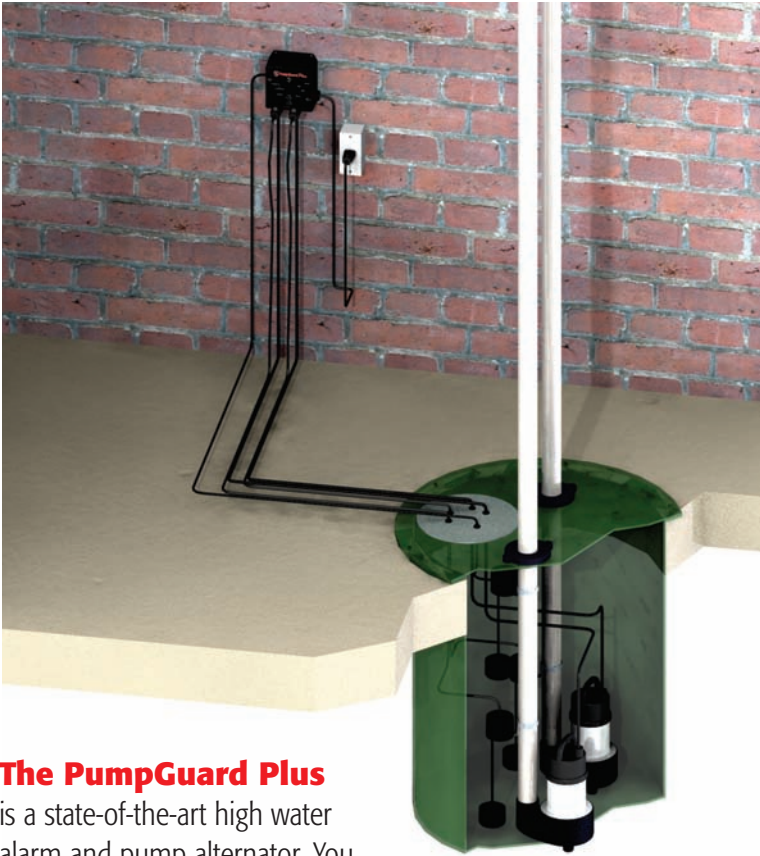

U.L. Listed

Dimensions

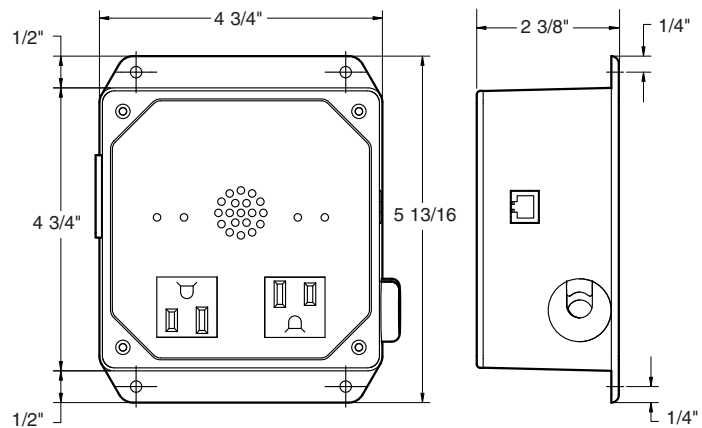

Shipping weight: 3.2 lbs

The PumpGuard Plus

is a state-of-the-art high water alarm and pump alternator. You will never worry about a bad pump again because the PumpGuard Plus alternates between the two pumps, each cycle, ensuring proper operation and wear. If a pump should fail, the PumpGuard Plus's override/alarm switch sounds the alarm, alerting you to the problem and then automatically activates the next pump in sequence, keeping your basement dry! The PumpGuard Plus is ideal for use with the SUMPRO Battery Back-Up System that will operate your entire pump system during a power outage.

OPTIONS

Phone Dialer

- Connect your PumpGuard Plus to our available phone dialer for notification of an emergency via any combination of telephones, cellular phones and pagers
- Dialer will call up to nine different numbers using your pre-programmed, 40 second emergency message
- Dialer will override an occupied line for an emergency call
- Power failure alarm alerts you to a power outage



SUMPRO

- Install the fully-automatic 115V Sumpro Battery Back-Up System that operates on either AC or DC power
- Sumpro will operate your entire pump system during a power outage keeping your basement dry
- Provides ultimate protection against blackouts and/or brownouts



HYDROTECH
COATING SYSTEMS

13 Sloop Road,
Grand Isle, VT 05458
Telephone: (802) 318-1808

www.hydrotechcoatingsystems.com